

ELECTRICAL IMPEDANCE STRING PROBES FOR TWO-PHASE VOID AND VELOCITY MEASUREMENTS†

J. E. HARDY and J. O. HYLTON
Oak Ridge National Laboratory, Oak Ridge, TN 37830, U.S.A.

(Received 13 July 1982; in revised form 12 April 1983)

Abstract—An instrumentation system was developed to measure two-phase flow velocity and void fraction. The principle of operation of this system was based on the measurement of the electrical impedance of two-phase mixtures. Two-phase velocity is estimated by time-of-flight analysis of signals from two spatially separated sensors. A technique involving measurement of both the capacitance and the conductance of the mixture was used to determine void fraction and correct for the effect of liquid distribution. The string probe instrumentation proved to be durable in air/water and steam/water flows and demonstrated an ability to measure a wide range of flow velocities (1–17 m/s) and void fractions (0.25–0.99+).

1. INTRODUCTION

A joint program to study three-dimensional thermohydraulic phenomena in the vessel (core, downcomer, and upper plenum) of a pressurized-water reactor (PWR) during the reflood stage of a loss-of-coolant accident (LOCA) was initiated by the U.S. Nuclear Regulatory Commission in cooperation with its counterparts in West Germany and Japan. The role of Oak Ridge National Laboratory (ORNL) was to develop, fabricate and supply instrumentation systems for measurement of three-dimensional two-phase (steam/water) flow parameters in two German and two Japanese nonnuclear reflood test facilities (Eads *et al.* 1977). These parameters include incore fluid flow, deentrainment in the upper plenum, and liquid fallback from the upper plenum into the core. More specifically, liquid film thickness and velocity, along with two-phase flow velocity and void fraction, must be measured. The subject of this paper is an instrumentation system that has been developed to measure two-phase flow velocity and void fraction in free-field flows.

The instrumentation scheme was based on the principle of measuring the electrical impedance of a two-phase mixture. The electrical conductivity and permittivity of steam (or air) and water are quite different; thus, as the two-phase flow structure at the point of measurement varies, so does the measured impedance. A probe (consisting of a pair of stainless steel electrodes) is situated in the flow stream and the electrical impedance of the two-phase mixture between the electrodes is measured. This measured impedance can be used to determine the local void fraction by employing a relative capacitance technique and accounting for flow distribution effects using the effect of conductance upon the impedance phase angle. By cross-correlating the output of two axially separated impedance probes, the velocity and direction of flow can be determined.

Although several types and configurations of impedance probes have been developed under this program (Eads 1977), this report will deal with one type in particular, a "string" probe. This probe consists of a pair of stainless steel wires (electrodes) strung back and forth across a rectangular stainless steel frame; thus, a string probe. A similar probe design was used by Carrard & Ledwidge (1971). The string probe was designed and fabricated

†Research sponsored by Division of Reactor Safety Research, U.S. Nuclear Regulatory Commission under Interagency Agreements DOE 40-551-75 and 40-552-75 with the U.S. Department of Energy under contract W-7405-eng-26 with the Union Carbide Corporation.

to operate under severe thermohydraulic conditions: temperatures up to 350°C, thermal transients of 300°C/s, and fluid shocks induced by condensation and flow reversals. The sensor is to be located in the larger flow areas in a test vessel (i.e. upper plenum, end box, or downcomer). Using a bi-level string probe (bi-level design affords velocity measurement) in the flow field and associated signal conditioning electronics, the instrument package was capable of measuring voids ranging from 0.25 to 0.99+ and two-phase flow velocities from 1 to 17 m/s. The data reduction techniques for void fraction and velocity are such that transient information can be processed. This capability was a must since refill-reflood experiments are transient tests.

2. STRING PROBE INSTRUMENTATION

The string probe instrumentation package was required to measure voids from 0 to 1.0 and two-phase flow velocities from 1 to 15 m/s. The sensor must operate in a hostile environment and in high magnetic and electric fields.

2.1 Measurement concept

The determination of void fraction from electrical impedance measurements has been widely applied for water-gas mixtures. Pioneering work in this area was undertaken by Orbeck (1962) using impedance void meters. Many of the basic techniques and early work with this method are reviewed by Hewitt (1978). The procedures described in this study generally follow the well established capacitance methods with one important exception. The electronics were deliberately designed so that the conductive and the capacitive components of the liquid phase are roughly the same magnitude. The capacitance is used to determine void fraction in the usual way. The effect of the conductance upon the impedance phase angle was used to estimate the distribution of the liquid phase and hence its influence on the capacitance-void fraction relationship.

The impedance of a two-phase mixture sensed by the electrodes of a probe depends both upon the volume fraction and distribution of the phases. It also depends upon the individual phases' electrical properties (conductivity and permittivity). Thus, in order to determine the volume fraction from the impedance measurement the instrumentation system must be able to detect and correct for these additional effects.

The admittance (inverse of the impedance), Y , of a two-phase mixture can be described by a complex number whose real part is the conductance (G) and whose imaginary part is the susceptance (ωC) where C is capacitance and ω is the angular frequency of excitation.

$$Y_{\text{mix}} = G_{\text{mix}} + j\omega C_{\text{mix}} = |Y| e^{j\theta}, \quad [1]$$

where θ is the phase angle. For a fluid such as water, the conductivity, σ_L and the dielectric constant, ϵ_L , of the liquid phase are much larger than σ_v and ϵ_v of the vapor phase and the following approximations can be made:

$$G_{\text{mix}} = \frac{\sigma_m}{B} \quad [2]$$

$$C_{\text{mix}} = \frac{\epsilon_m}{B}, \quad [3]$$

where σ_m is the average mixture conductivity, ϵ_m is the average mixture capacitance and B is a constant which is determined by the geometry of the electrodes.

The probe electronics, by measuring the magnitude and phase of the admittance,

permit the determination of σ_m and ϵ_m . The mixture conductivity, σ_m , is a function of σ_L and σ_g ; and the mixture capacitance, ϵ_m , is a function of ϵ_L and ϵ_g . For the relatively high void fraction conditions expected in a reflood environment, the assumptions of $\sigma_g = 0$ and $\epsilon_g = 1.0$ are valid. The liquid conductivity (σ_L) is strongly influenced by temperature and ion concentration and can vary by orders of magnitude, whereas the dielectric constant is relatively insensitive to dilute ion concentrations and varies from approx. 80–40 over the expected temperature range during the reflood test.

Assuming that ϵ_m varies linearly between ϵ_L and ϵ_g as the void fraction changes from 0.0 to 1.0 leads to the following linear relationship:

$$\alpha_c = \frac{\epsilon_L - \epsilon_m}{\epsilon_L - \epsilon_g} \simeq \alpha_T. \quad [4]$$

This "relative capacitance" void fraction, α_c , is a good approximation of the true void fraction, α_T , in many two-phase flow applications. It is true, however, that the linear relationship is not always valid and that the probe calibration is affected by phase distributions (flow regimes). In fact, for the same mixture capacitance, several void fraction values are possible.

A technique was developed to identify the flow regime at the sensor so that the appropriate calibration curve could be selected and, thus, the correct void fraction. This technique involved the use of the value of the phase of the probe impedance to select the correct flow regime curve. A correction is applied to the relative capacitance void value according to the flow regime present. A more detailed explanation of this method is given by Hylton & Muller (1980) and Hylton & McGill (1981).

For the string probe instrumentation described in this report, the capacitive portion of the output impedance probe signal was used in [4] to determine the two-phase mixture void fraction. A probe geometry was selected so as to be sensitive to two-phase flow in free-field conditions.

The string probe instrumentation measures a two-phase flow velocity using a technique of analysis of random signals from two spatially separated impedance probes. The basic nature of two-phase flow is chaotic with random flow disturbances caused by gas-liquid interfaces (bubbles, slugs, droplets or waves). These passing interfaces induce fluctuations in the measured mixture impedance (and output signal). As the flow perturbations travel in the two-phase mixture they may be "sensed" by axially separated sensors. There will be a delay between the time when the upstream probe "sees" the disturbances and the downstream probe records their presence. By taking the Fourier transform of the signals from each impedance probe, the transfer function between the signals can be determined. If the phase of the transfer function (θ) is plotted against frequency (f) and a simple time delay is present in the system, a linear curve will result. The slope of this curve is equivalent to the dominant time delay, τ , between the two signals ($d\theta/df = \theta$). Thus, the transport time is:

$$\tau = \theta(f)/360. \quad [5]$$

The velocity of the perturbations, V , is then computed by:

$$V = D/\tau, \quad [6]$$

where D is the separation distance between impedance probes. Several points must be noted at this time. First, a dominant transport time is found by this method. This yields an average of the perturbation velocities for the period under study. Secondly, this

technique measures velocities of fluctuations in the flow, not necessarily a particular phase velocity. In pure bubble flow, this method will measure an average bubble velocity which corresponds to the vapor velocity. Similarly, in droplet flow an average droplet velocity will be measured which corresponds to the liquid phase velocity. However, in the slug or froth flow regimes, the gas-liquid interface velocities are not necessarily the phase velocities. In annular-mist flow, there are two flow interfaces, droplets and waves on the film, both of which can influence the velocity measurement.

Third, of some concern in interpreting the velocity measurement was the influence of the probe body on the flow passing through the open areas of the electrode planes. Early experimentation with different probe geometries showed that these effects could be minimized by maintaining a sufficient ratio of open area to total cross sectional probe area. An additional factor that helped in minimizing the effects of local disturbances or circulation patterns is that these flow phenomena tended to be of low coherence and were not measured by the cross correlation technique.

Finally, there is not a way to detect if the flow disturbances are passing both sensor levels at 90° with respect to the wires. If this occurs, the calculated velocity would be in error since an incorrect distance would be used in the time-of-flight equation, [6].

The above points are true in general for impedance probe velocity measurements; but for the specific case of the string probe, they are not necessarily significant. In actual use, the string sensor will be located in open flow areas or in complex geometries. Annular-type flow probably will not exist within the string probe sensing region. Also, in most cases, high void fraction flows will predominate (dispersed droplet flow); and slug and froth flows will not occur as often. For most of the experimental work in this report, the string probe instrumentation monitored high void conditions and sensed liquid dominated perturbations.

To measure void fraction and velocity during a transient, the data is assumed to be steady-state (or constant) for a short period of time. The previously described techniques are applied for that short block of time to calculate void and velocity values and then the next block of data in time is analyzed. This next block of data overlaps the previous data set by a predetermined amount. The overlapping and size of time period are selected according to the speed of the transient and resolution of flow parameters required. Leavell & Mullens describe the transient velocity algorithm and show velocity estimates for several steam/water transients (Leavell & Mullens 1981).

2.2 Design and fabrication

A sensor was designed to withstand the severe environmental conditions and support two level of electrodes to afford void and velocity measurements. Previous work at ORNL has shown an axial spacing of 1.91 cm between the two electrode levels and an electrode-to-electrode spacing of 0.25 cm to be suitable for in-vessel measurements (Eads *et al.* 1977). With these criteria in mind, a string sensor was designed and fabricated as pictured in figure 1. The sensor consisted of a stainless steel frame that supported two levels of electrodes, stainless steel wires, and electrical insulators. Two wires are strung per level creating a pair of electrodes.

The stainless steel wires (strings) were electrically isolated from the sensor frame by a cermet (ceramic-metal bond) that was developed at ORNL. This cermet met the needs of high-temperature steam oxidation resistance and structural integrity after numerous thermal shocks (Moorhead *et al.* 1980).

2.3 Signal conditioning electronics

The function of the electronics system is to determine the impedance and change in impedance of a sensor located in two-phase flow field. The signal conditioning electronics

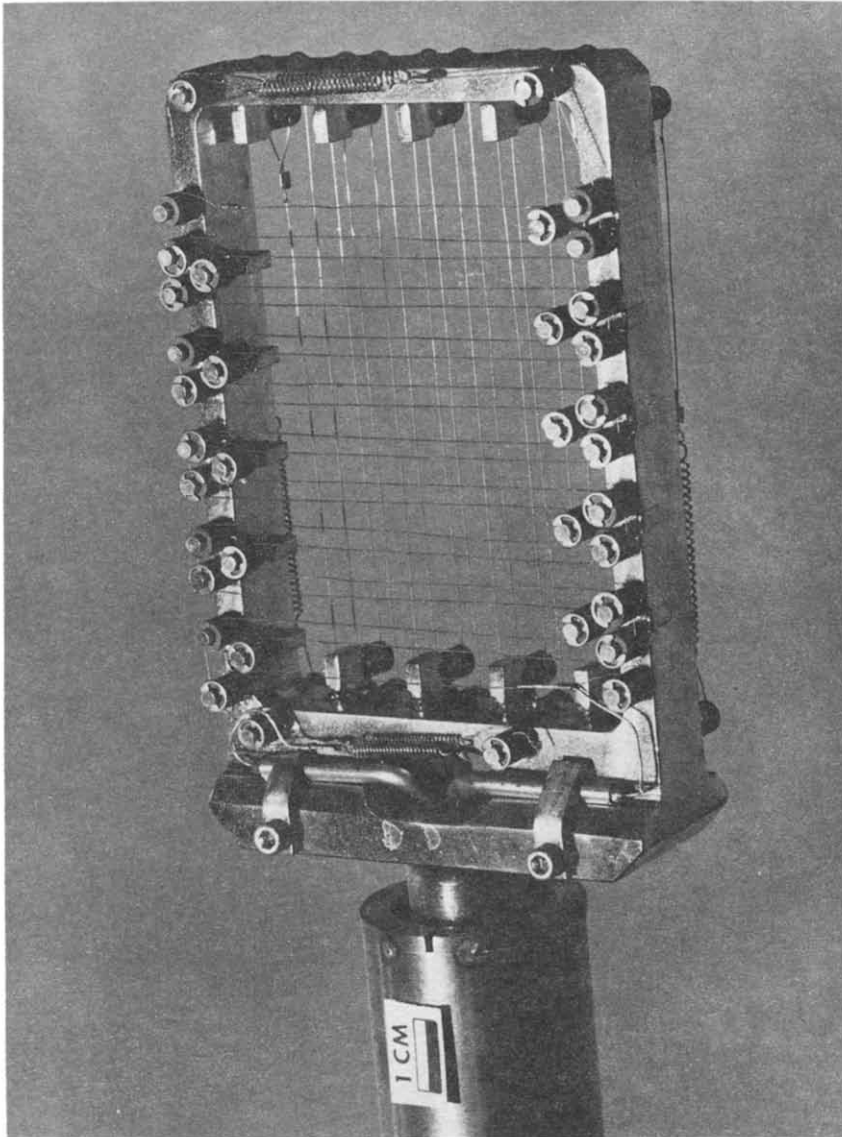

Figure 1. Photograph of a string probe with ceramic insulators (distance between electrode wires 0.25 cm, spacing between levels 1.90 cm).

provide one analog output signal proportional to the magnitude of the probe impedance and another analog output proportional to the phase of the probe impedance.

Since the string sensors are located in-vessel, cables must travel within the reflow environment and are subjected to high and variable temperatures. Equivalent cable capacitance can exceed 1 nF, two orders of magnitude greater than the probe capacitance (air-only values of 2.0–12.0 pF). The electronics provide a means to negate the cable capacitance by driving the inner cable shield and center conductor at the same potential. Thus, a capacitive charge is not built up. This technique has been shown to reduce the cable capacitance to an acceptable level for cables 20–30 m in length.

The electronics are sensitive enough to detect changes of capacitance between electrodes of a few femtofarads. This sensitivity allows small droplets of water to be sensed by the string probe even if the drops do not “bridge” the electrodes. Thus, very high void fractions and droplet velocities can be measured.

2.4 Calibration

Calibration of the string probe instrumentation system was divided into three areas: the signal conditioning electronics, the void fraction method, and the velocity measurement technique.

Known values of capacitors and resistors or a combination of both were used to simulate expected probe impedances in the two-phase flow. These simulated flow impedances were used to calibrate both the magnitude and phase circuits. Over the three orders of magnitude range tested, calculated impedance magnitude values were within $\pm 2\%$ of the standards.

A calibration of the void fraction method was accomplished by comparing the string probe results to the measured voids determined by a low-energy gamma densitometer. The accuracy of this densitometer was $\pm 3\%$ of reading. An *in situ* calibration was performed with well-homogenized mixtures covering a range of void fractions. A plot of the computed voids from both instruments is presented in figure 2. The agreement between the upper

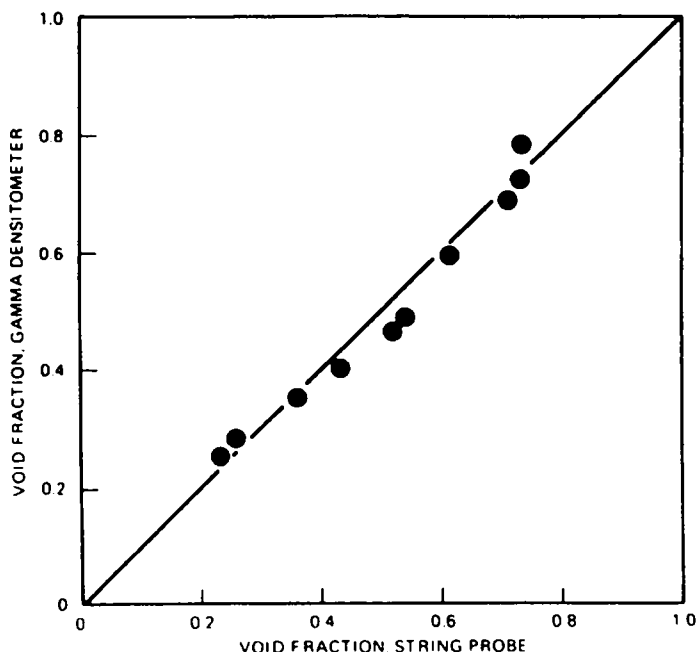

Figure 2. String probe void fraction calibration; comparison with low-energy gamma densitometer in air/water flow.

and lower sensors of the string probe was typically within $\pm 2\%$ void of each other. Unfortunately the facility available for this calibration work could not be operated to produce void fractions below 20 or above 80%. However, very good agreement was found between the sensors above a void fraction range of ~ 0.25 to ~ 0.80 .

Velocity calibration is a much more difficult task. Very few instruments measure phase velocities in two-phase flow without large uncertainties. Also, the string probe measures interface velocities which are not necessarily phase velocities. With these constraints, a vibrating capillary tube system was devised to generate single droplets of water. The droplet velocity was measured by adjusting the frequency of a strobe light until the drops appeared to be standing still. Then knowing this frequency and the spacing between drops the droplet velocity was calculated. This calculated value was compared to the cross correlation velocity from the impedance probe. The probe velocities agreed well (within $\pm 5\%$) with droplet velocities for a variety of drop sizes.

3. EXPERIMENTAL RESULTS

String probes were tested under steam/water and air/water flow conditions typical of those expected during the reflood stage of a LOCA. Three facilities were used to conduct the experiments: (1) a test stand that operated at pressures to 1000 kPa and temperature of 170°C and allowed cocurrent vertical upflow of a wide variety of steam and water flow rates; (2) three-module air/water instrument development loop (1-mod A/W IDL) that represented a full-scale vertical section of an upper plenum including air/water mixers, dummy rod bundles, end boxes, an upper core support plate (UCSP), and upper plenum structures (this facility afforded the capability of water injection into the vessel at either the hot leg or the core location with air entering through air/water mixers at the core location, the test vessel was constructed of plexiglas to allow flow visualization); and (3) a single-module steam/water IDL (1-Mod S/W IDL) (a similar version of the air/water facility) that operated over a wide range of pressures, 200–700 kPa. Most tests in these facilities were high void fraction in nature with dispersed flow (froth or droplet) regimes.

The string probe tested in facilities (1) and (2) was 7.1×9.8 cm with a free flow area of 48 cm². The sensor used in the 1-Mod S/W IDL was 4.5×4.5 cm with a free flow area of 10.5 cm².

3.1 Void fraction measurement

The test section illustrated in figure 3 was employed for testing string probes in the steam/water test stand. Void fraction results from the string probe were compared to composite void values from a three-beam gamma densitometer. The accuracy of the composite density produced by the three-beam densitometer was $\pm 5\%$ of reading.

Figure 4 compares data obtained with the string probe at the two levels with data from the gamma densitometer. The difference observed in the measured voids at the two probe levels is small with the upstream (lower) level usually yielding a higher void value. This may be caused by small amounts of water collecting on the top of the frame, slightly lowering the downstream level's output. The void fractions determined by the string sensor increase uniformly with the densitometer values. The string probe void fraction slightly overpredicts the densitometer output in the void range from 0.5 to 0.95; for $\alpha > 0.95$ the trend reverses and the densitometer measurements are somewhat higher than the string probe readings. These discrepancies may be caused, in part, by the changing flow area between the string sensor location and the gamma densitometer position (figure 3) or the reduced sensitivity of the densitometer at high void fractions.

The string probe was installed in the upper plenum of the 3-Mod A/W IDL, 18 cm above the UCSP (figure 5). Most of the experimental runs were conducted with the probe centerline ~ 2 cm from the vessel centerline. One series of tests was run with the probe

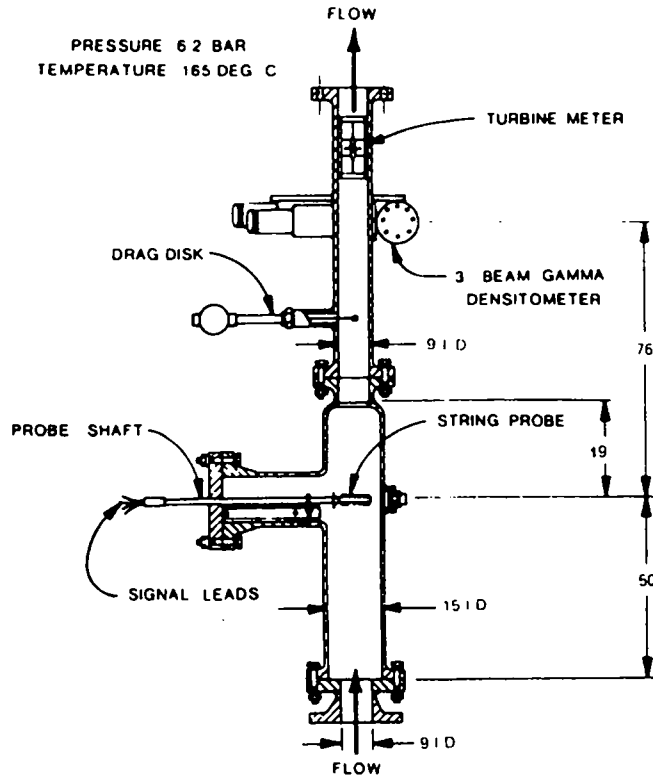

Figure 3. Configuration for testing of string probes in steam/water test stand (all dimensions in centimeters).

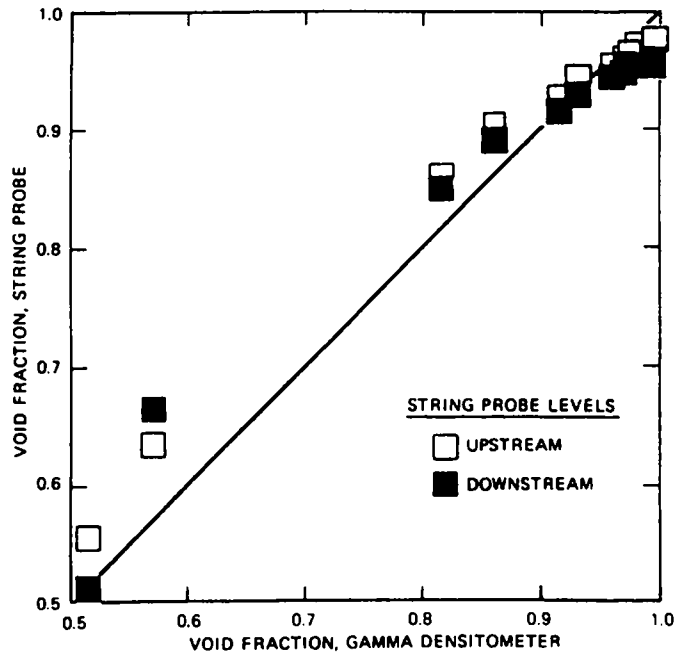

Figure 4. Void fraction comparison for the string probe and three-beam gamma densitometer in the steam/water test stand (both levels of string sensor presented).

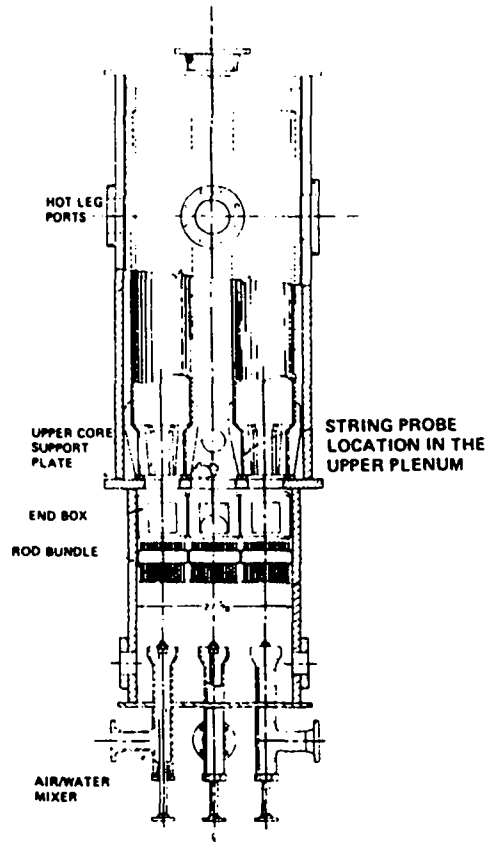

Figure 5. Schematic diagram of the 3-Mod A/W IDL with test location of string probe noted.

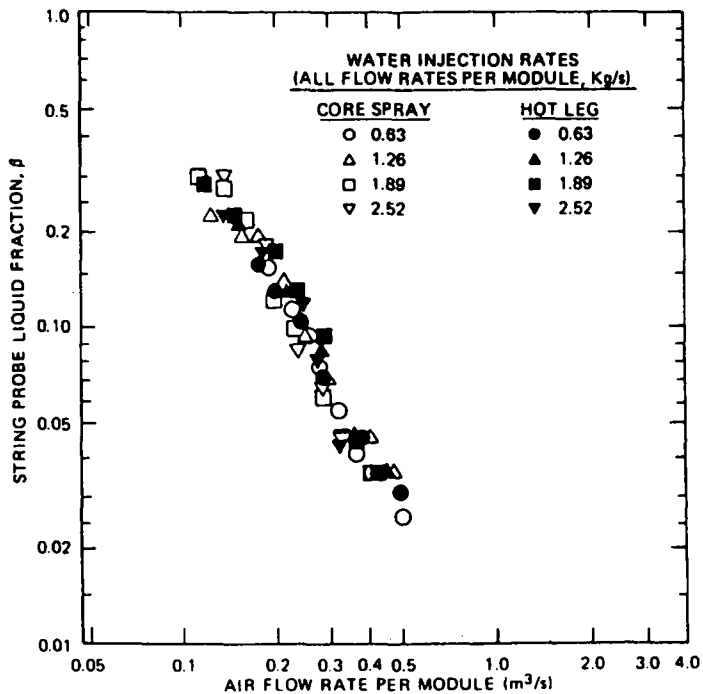

Figure 6. String probe liquid fraction data for two types of water injection in the 3-Mod A/W IDL upper plenum.

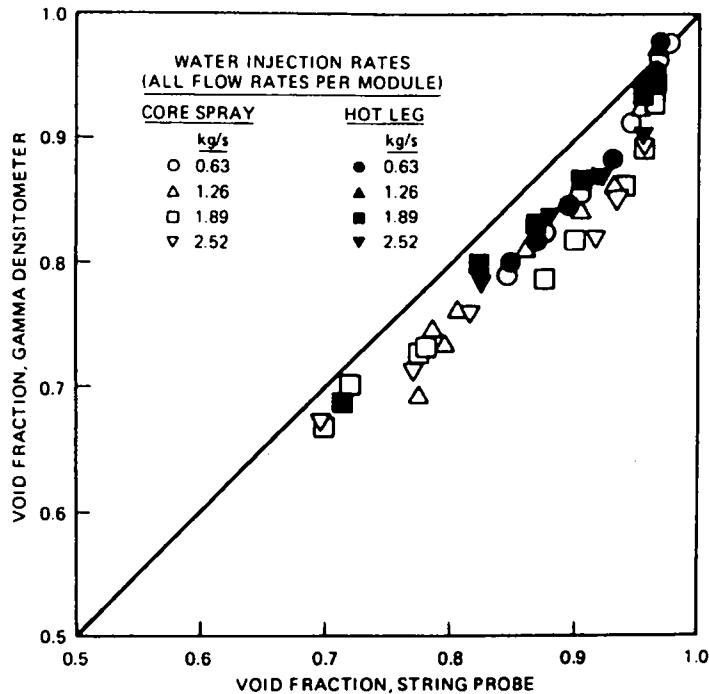

Figure 7. String probe void data compared to gamma densitometer void values from the upper plenum of the 3-Mod A/W IDL.

positioned 6 cm from the wall, ~ 12 cm from the vessel centerline. Liquid fraction data β (i.e. $1 - \alpha$) from the string sensor are plotted as a function of air flow rate in figure 6. The trend in the data shows the drying out of the upper plenum with increasing air flow. This drying out was confirmed by visual observations and an *in situ* low-energy gamma densitometer located 50 cm above the UCSP. The void data appeared to be independent of water injection rates. This result was confirmed by the low-energy densitometer data and a collapsed liquid level measurement. A comparison of the void fraction results from the densitometer and string probe is presented in figure 7. Generally good agreement is shown for void fractions between ~ 0.70 and 0.98 . The string probe consistently measured a higher void than did the densitometer. This result was not surprising in that the string sensor monitored flow near the center of the upper plenum whereas the densitometer measurement was an average from the vessel centerline to the wall. For a majority of flow combinations, water tended to collect on upper plenum surfaces, especially walls. The densitometer apparently sensed this flow distribution; but the string sensor, being a more local measurement, did not. This suspected density profile was further confirmed when data was taken with the string probe closer to the wall (figure 8); a significant increase in the two-phase mixture density was noted closer to the wall, as expected.

The string probe was positioned in the end box of the 1-Mod S/W IDL over a 3×3 hole array of the tie plate. Experiments were run with various water core spray rates and steam flows at several system pressures. The liquid fraction in the end box as a function of test section steam flow is presented in figure 9. The liquid fraction decreased (void fraction increased) as the steam flow rate increased. The measured liquid fraction was sensitive to core spray rate; the lower the rate, the lower the liquid fraction. These data were taken at 450 kPa; similar values were recorded at system pressures of 210, 330 and 690 kPa. The results of these steam/water tests showed that a wide range of liquid fractions could be measured, $\beta = 0.0015$ to 0.75 , in a complex flow field; data scatter was small for a given core spray rate, and data were reproducible (data were collected for over a year).

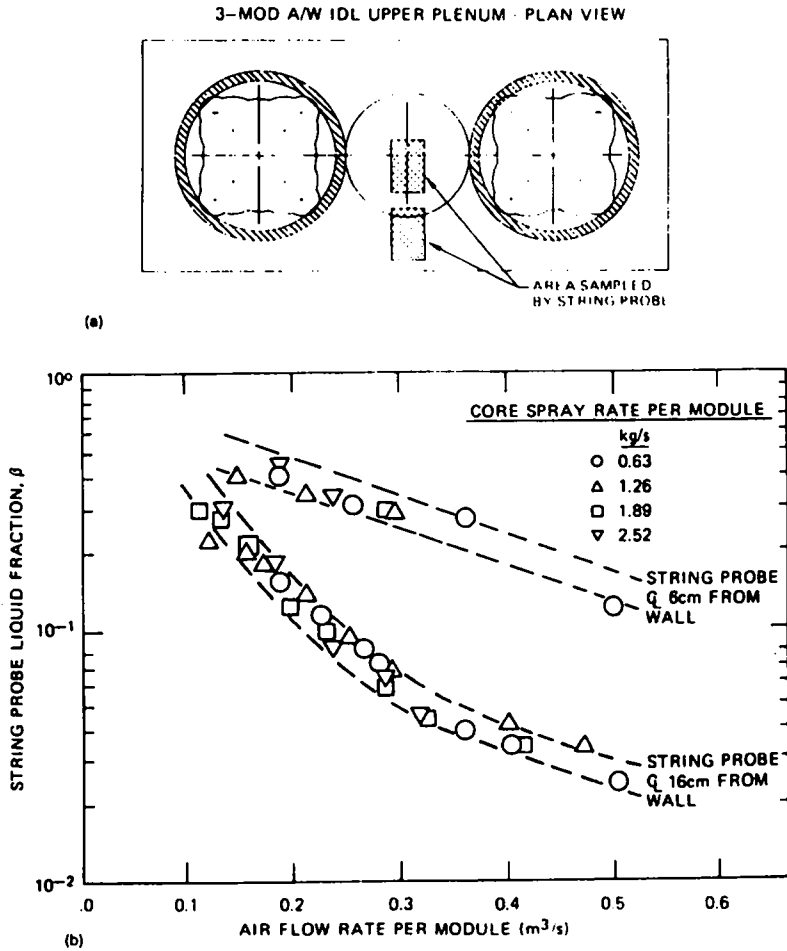

Figure 8. (a) Location of string probe in the upper plenum of the 3-Mod A/W IDL. (b) Variations in liquid fraction as measured by a string probe in the upper plenum.

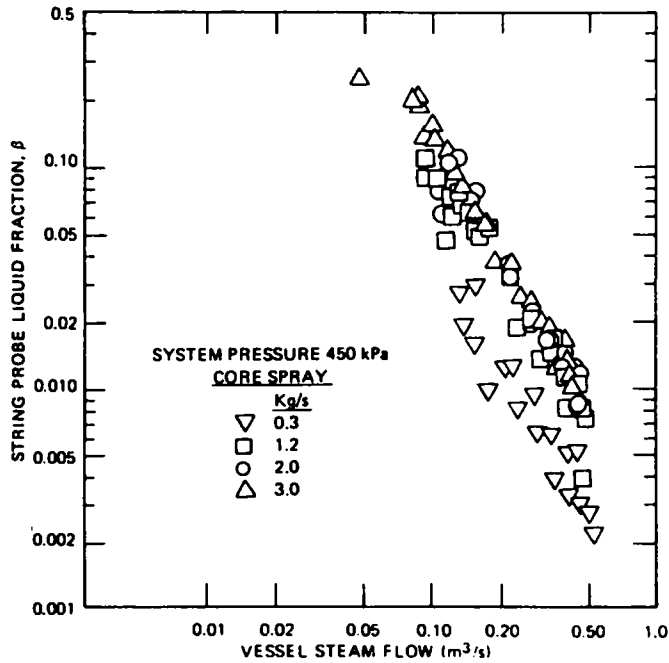

Figure 9. String probe liquid fraction data from the end box of the 1-Mod S/W IDL at 450 kPa.

3.2 Velocity measurement

Velocity data from the string probe were compared to phase velocities and turbine meter velocities with the understanding that a correlation between these may not exist in some flow regimes. Previous studies, (Jallouk & Hardy 1977; Sheppard *et al.* 1976), with turbine meters have shown that at high-void conditions turbines are more sensitive to the gas phase; while at low void flows, turbine meters react more to the liquid phase. In intermediate void fraction flow, e.g. slug flow regime, the response of turbine meters is not well understood; theories have been proposed, but none are widely accepted.

Three established turbine meter models were investigated by Turnage *et al.* (1979); the Aya, the Rouhani, and the volumetric model in two-phase vertical upflow. At lower air flows (below 3 m/s), the three turbine meter expressions reasonably predicted the correct turbine speed. However, at higher air flow rates (above 6 m/s), the turbine models did not even predict the correct trend in turbine velocities as water flow rates increased at a constant air flow. The string probe measures interfacial velocities [e.g. in low void fractions (bubble flow) a gas-phase velocity is measured and in high-void flows (droplet) a liquid-phase velocity is measured].

A comparison of measured velocities in the steam/water test stand for the string sensor and turbine meter is presented in figure 10. For string probe velocities below ~ 2 m/s, turbine velocities between 2 and 5 m/s, the predominant flow regime was slug. Because it is unclear as to what velocity each instrument is monitoring in this regime, comparisons are difficult. As velocities increased, the string probe values approached the turbine meter velocities. At these conditions, dispersed flow was prevalent; and the slip ratio, S , approached 1 as the void fraction approached one. For this reason, the string sensor (measuring droplet velocities) and the turbine meter (sensitive to the vapor velocity) yield velocities of approximately equal magnitudes.

Velocity data from the string probe were also compared to liquid-phase velocities

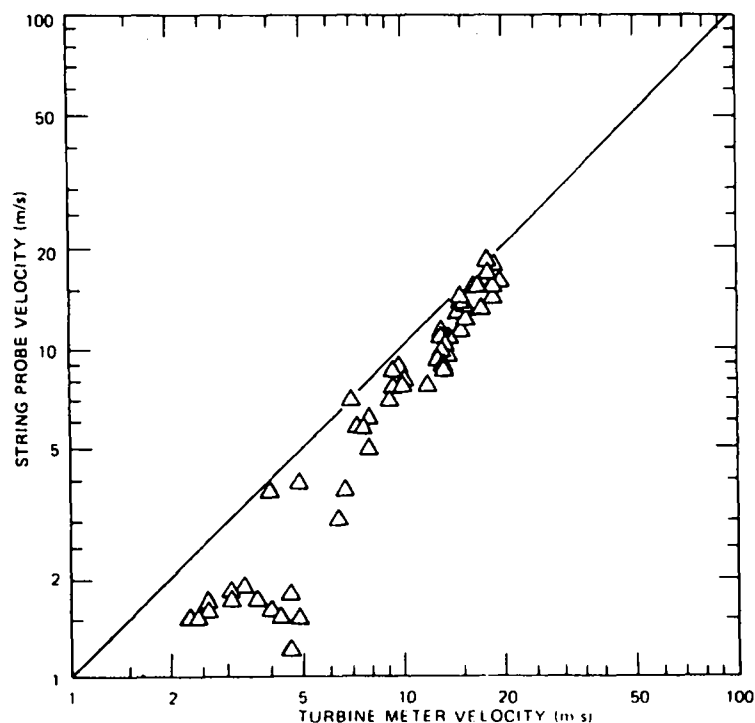

Figure 10. Comparison of string probe and turbine meter velocities in steam/water test stand.

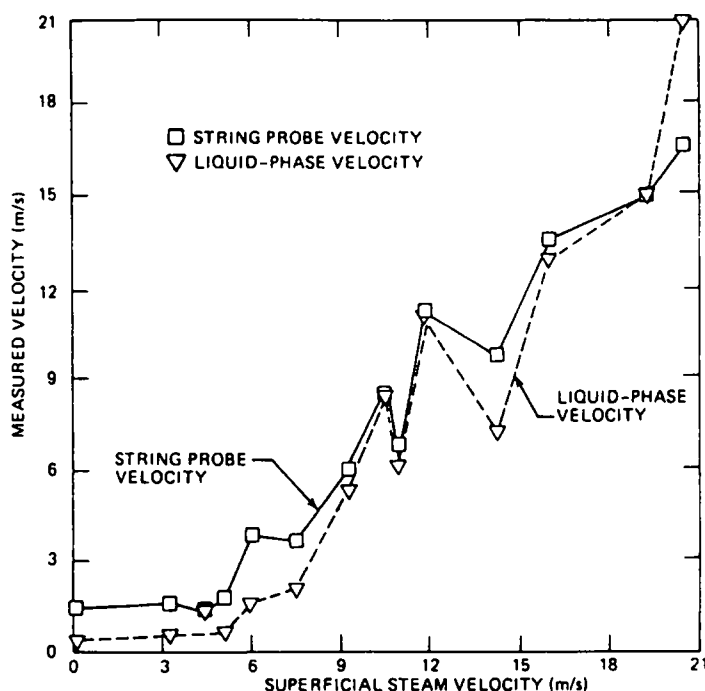

Figure 11. Liquid-phase velocity compared with string sensor velocity as a function of superficial steam velocity in the steam/water test stand.

calculated from measured loop parameters using the separate-flow model (figure 11). At velocities below 6 m/s, the string probe measures a gas-phase velocity which should be greater than the liquid-phase value (the slip ratio in vertical upflow is nominally 1–1.2). String probe data above 6 m/s are in very good agreement with the liquid-phase velocity as expected from previous arguments.

Velocity data were taken with the string probe installed in the end box of the 1-Mod S/W IDL at various core spray rates and pressures. Along with the string sensor, a turbine meter that covered a single flow hole of the tie plate was monitored. The turbine velocities were plotted against string probe velocities and are shown in figure 12. The turbine meter values are consistently larger than the string probe numbers. At the higher and lower velocities (and flow rates), the turbine meter velocity approached the string probe value. At the low velocity-flow conditions, the slip ratio is close to one; and the two instrument outputs should be approximately equal. In high velocity-high void flows, the string probe senses liquid perturbations (droplets); while the turbine meter is driven primarily by the continuous gas phase. However, once again the slip ratio is approximately one (phase velocities approach each other), and turbine and string sensor velocities converge. This trend is similar to one found in the steam/water test stand (figure 10).

To aid in understanding the string sensor velocity, the probe data were compared using a liquid volumetric flow term defined as the core spray flow rate, Q_f , divided by the string probe liquid fraction. Because of the complicated geometry in the loop, an approximate flow area was difficult to select; thus, the volumetric flow was used. However, functional dependency on velocity still should be evident, if it occurs, since the flow area is a constant. The string probe velocity data are shown as a function of the liquid volumetric term in figure 13. The 1.2, 2.0 and 3.0 kg/s core spray data collapsed to a single curve independent of system pressure with relatively little scatter.

The 0.3 kg/s data were substantially lower than the data at the other flow rates; this result may relate to the significantly higher void fraction observed in the end box for the

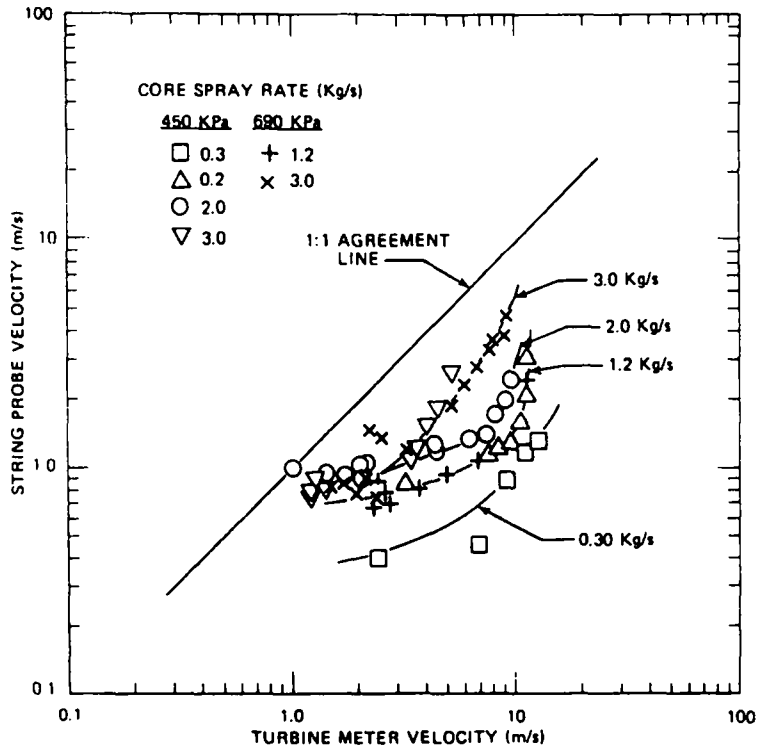

Figure 12. Velocity comparison of the string probe and turbine meter in the end box of the 1-Mod S/W IDL.

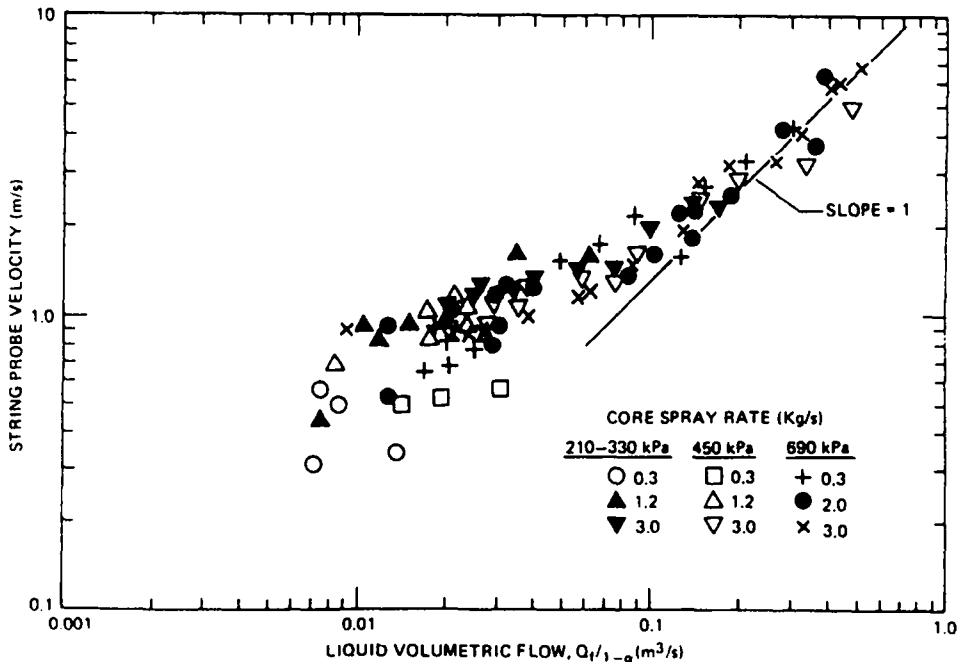

Figure 13. String probe velocity versus liquid volumetric flow in the end box of the 1-Mod S/W IDL for various core spray rates.

0.3 kg/s core spray rate (figure 9). At the higher liquid volumetric flow values ($Q_f/(1 - \alpha) > 0.15$), the curve approached a slope of one, suggesting that the string probe is indeed monitoring the liquid velocity in the end box at the high flow-high void conditions.

4. SUMMARY OF RESULTS

A string sensor has been designed and fabricated to withstand the severe environment of a reflood test facility. Survivability testing has included two years of operation in a high velocity-steam/water environment, structural integrity tests with high velocity water impinging on the sensor, and thermal shock testing of the cermet insulators.

The impedance of a two-phase mixture has been successfully measured by the instrumentation over a wide range of values. This impedance has been converted to void fraction value using a relative capacitance technique. Comparisons of the data from a gamma densitometer and the string probe have shown excellent agreement between the relative capacitance values and the densitometer voids. The void fraction technique is capable of compensating for media property changes (i.e. dielectric constant and conductivity). The string probe functioned well in air/water and steam/water with measurements being made over a range of voids from 25 to 99.9%.

Encouraging results were also obtained for measurement of flow velocities by the string sensor instrumentation. The string probe measured velocities over the range from 0.5 to 17 m/s with reasonably good reproducibility. In low-void-fraction flows, the sensor appeared to monitor vapor phenomena. At high void conditions, the measured velocity by the sensor tended to track liquid phenomena. Additional work is required to understand more fully the velocity values indicated by the probe, especially in slug and froth flow regimes.

In general, the string probe instrumentation package was able to measure a large range of flow velocities (1.0–17 m/s) and void fractions (0.25–0.999), gave data that were repeatable, was robust enough to withstand the two-phase flow environment, and was reliable.

Acknowledgements—This research was performed at the Oak Ridge National Laboratory which is operated by Union Carbide for the Department of Energy. This work was under the sponsorship of the U.S. Nuclear Regulatory Commission.

REFERENCES

- CARRARD, G. and LEDWIDGE, T. J. 1971 Measurement of slip distribution and average void fraction in an air-water mixtures. *Int. Symp. on Two-Phase Systems*, Paper 3–13. Haifa, Israel.
- EADS, B. G. *et al.* 1977 Advanced instrumentation for reflood studies program quart. prog. rep. 1 October–3 December 1977. ORNL/NUREG/TM-202.
- HEWITT, G. F. 1978 *Measurement of Two-Phase Flow Parameters*, pp. 57–60. Academic Press, London.
- HYLTON, J. O. and MULLER, R. C. 1980 Impedance probe void fraction measurements. *Proc. Review Group Conf. on Advanced Instrumentation Research For Reactor Safety*, pp. IV. 11–1 to 11–21, NUREG/CP-0015. Oak Ridge, Tennessee.
- HYLTON, J. O. and MCGILL, R. N. 1981 Measurement of velocity and void fraction in steam-water mixtures with electrical impedance probes. *Proc. OECD (NEA) CSNI 3rd Specialists Meeting on Transient Two-Phase Flow*, CSNI Rep. No. 61. Pasadena, California.
- JALLOUK, P. A. and HARDY, J. E. 1977 Advanced two-phase instrumentation program quart. prog. rep. October–December 1977. ORNL/NUREG/TM-227.

- LEAVELL, W. H. and MULLENS, J. A. 1981 Computation of transient phase interface velocities in liquid-vapor mixtures, flow: its measurement and control in science and industry. *2nd Int. Symp.*, St. Louis, Missouri.
- MOORHEAD, A. J. *et al.* 1980 Fabrication of sensors for high-temperature steam instrumentation systems. NUREG/CR-1359/ORNL/NUREG-65.
- ORBECK, I. 1962 Impedance Void Meter. Institutt for Atomenergie, Kjeller Research Establishment, Norway, Report KR-32.
- SHEPPARD, J. D. *et al.* 1976 An experimental study of flow monitoring instruments in air-water, two-phase downflow. *Presented at CREST Specialists Meeting on Transient Two-Phase Flow*, Toronto, Canada.
- TURNAGE, K. G. *et al.* 1979 Advanced two-phase flow instrumentation program quart. prog. rep. January-March 1979. NUREG/CR-0847/ORNL TM-331.